



Macintosh Performa 400 Series

Macintosh Performa 400/405, Macintosh Performa 410, Macintosh Performa 430, Macintosh Performa 450, Macintosh Performa 460/466/467, Macintosh Performa 475/476





Specifications

Macintosh Performa 400 Series





Processor

Performa 400/405/ 410/430

Motorola 68030 microprocessor
16 MHz
16-bit internal data bus
Burst-mode RAM access

Performa 450

Motorola 68030 microprocessor
25 MHz
32-bit internal data bus
Burst-mode RAM access
Coprocessor socket





**Performa 460/466/
467**

Motorola 68030 microprocessor
33 MHz
32-bit internal data bus
Burst-mode RAM access
Coprocessor socket

Performa 475/476

Motorola 68LC040 microprocessor
25 MHz
32-bit internal data bus
Burst-mode RAM access





Memory

DRAM	Performa 400/405/410/430: 4 MB standard, expandable to 10 MB (100 ns or faster SIMMs) Performa 450: 4 MB standard, expandable to 36 MB (80 ns or faster SIMMs)
ROM	Performa 460/466/467: 4 MB standard, expandable to 36 MB (80 ns or faster SIMMs) Performa 475/476: 4 MB or 8 MB standard, expandable to 36 MB (80 ns or faster SIMMs) Performa 400/405/410/430: 512 K Performa 450/460/466/467/475/476: 1MB





VRAM

Performa 400/405/410/430: 512K VRAM SIMM

Performa 450: 512K VRAM SIMM, upgradable to 768 MB

Performa 460/466/467: 512K VRAM, upgradable to 768 MB

Performa 475/476: 512K VRAM SIMM, upgradable to 1 MB





Disk Storage

Floppy Drive

Performa 400/405/430: Apple SuperDrive 1.4 MB Floppy Disk Drive

Performa 410: Apple SuperDrive Manual Insert Floppy Disk Drive

Performa 450: Apple SuperDrive 1.4 MB Floppy Disk Drive

Performa 460/466/467: Apple SuperDrive Manual Insert Floppy Disk Drive

Performa 475/476: Apple SuperDrive 1.4 MB Floppy Disk Drive or Apple SuperDrive Manual Insert Floppy Disk Drive





Hard Drive

Performa 400: 40 or 80 MB

Performa 405/410: 80 MB

Performa 430: 120 MB

Performa 450: 120, 80 MB

Performa 460: 80, MB

Performa 466/467/475: 160 MB

Performa 476: 160 or 230 MB

Note: Hard drive configurations at computer introduction.





I/O Interfaces

Serial	Two RS-232/RS-422 serial ports; mini DIN-8 connectors
SCSI	SCSI interface; DB-25 connector
Apple Desktop Bus	One ADB port; mini DIN-4 connector
Video	One DB-15 monitor port for built-in video; DA-15 connector
Sound	Sound input port for monaural sound input; mini phono plug Performa 475/476: mono sound input port, stereo output port; mini phono plug



**Expansion
Connector**

Performa 400/405/410/430: 96-pin processor-direct slot (PDS) supporting 020/030 direct slot expansion card

Performa 450: 114-pin PDS supporting 020/030 direct slot expansion card

Performa 460/466/467: 114-pin PDS supporting 020/030 direct slot expansion card

Performa 475/476: 114-pin expansion slot supporting 030/040 expansion cards. Accepts Macintosh LC compatible I/O display, network, and video capture cards. Does not support 030 processor accelerator or cache cards.





I/O Devices

Keyboard

Apple Keyboard, Apple Keyboard II, Apple Extended Keyboard II or Apple Adjustable Keyboard connected through ADB ports (mini DIN-4)

Mouse

ADB mouse and Apple Desktop Bus Mouse II connected through ADB ports (mini DIN-4)

Microphone

Electret, omnidirectional
Operates on 8 VDC supplied by microphone port on CPU





Sound and Video

Sound

Monaural, 8-bit sound input at 11 or 22 KHz

Monophonic, 8-bit sound generator supplying same signal to both channels of stereo equipment



**Video**

Performa 400, bundled with Performa Display.39 VGA monitor

Performa 405, bundled with Performa Display.39 VGA monitor

Performa 430, bundled with Performa Display Plus.29 VGA
monitor

Performa 410, bundled with Performa Display.39 VGA monitor

Performa 450, bundled with Performa Display Plus.29 VGA
monitor

Performa 460, bundled with Performa Display.39 VGA monitor

Performa 466/467, bundled with Performa Display Plus.29 VGA
monitor

Performa 475/476, bundled with Performa Display Plus.29 VGA
monitor





Electrical

Line Voltage	100–240 VAC, automatically configured
Frequency	50–60 Hz
Maximum Power	Performa 400: 50 W (not including monitor) Performa 450: 30 W Performa 475/6: 26 W





Physical

Dimensions

Height: 3.0 in. (7.7 cm)

Width: 12.2 in. (31.0 cm)

Depth: 15.0 in. (38.2 cm)

Weight

8.8 lb. (4.0 kg)





Troubleshooting

Macintosh Performa 400 Series





General

The Symptom Charts included in this chapter will help you diagnose specific symptoms related to your product. Because cures are listed on the charts in the order of most likely solution, try the first cure first. Verify whether or not the product continues to exhibit the symptom. If the symptom persists, try the next cure. (Note: If you have replaced a module, reinstall the original module before you proceed to the next cure.)

If you are not sure what the problem is, or if the Symptom Charts do not resolve the problem, refer to the Flowchart for the product family.

For additional assistance, contact Apple Technical Support.





Symptom Charts

Error Chords

Eight-tone error chord sounds during startup

- 1 Replace SIMMs.
- 2 Replace logic board. Retain customer's SIMMs.
- 3 Perform SIMM verification on replacement logic board.

Four-tone error chord sounds during startup

- 1 Disconnect hard drive power cable and hard drive data cable and reboot system. If startup sequence is normal, run "Macintosh Hard Disk Test" and replace hard drive if necessary.
- 2 Disconnect floppy drive cable and reboot system. If startup sequence is normal, replace floppy drive.
- 3 Replace logic board. Retain customer's SIMMs.





Built-in Video

No video

Check batteries. See “Battery Verification” in Additional Procedures.

Screen is dark, audio and at least one drive operate, fan runs, and LED is lit

- 1 Adjust brightness on monitor.
- 2 Replace monitor. Troubleshoot defective monitor. See Symptom Charts in appropriate monitor manual.
- 3 Replace video cable.
- 4 Replace VRAM SIMM.
- 5 Replace logic board. Retain customer’s SIMMs.
- 6 Replace power supply.

Screen is dark, audio and drive do not operate, but fan runs and LED is lit

- 1 Remove expansion card, if present
- 2 Remove peripherals.
- 3 Replace SIMMs. Refer to Hardware/Memory.
- 4 Replace logic board. Retain customer’s SIMMs.
- 5 Replace power supply.





Partial or whole screen is bright and audio is present, but no video information is visible	<ol style="list-style-type: none">1 Replace video cable.2 Replace monitor.3 Replace logic board. Retain customer's SIMMs.
Screen is completely dark, fan is not running, and LED is not lit	<ol style="list-style-type: none">1 Check batteries. See "Battery Verification" in Additional Procedures.2 Plug monitor directly into wall socket. Verify that monitor has power.3 Remove expansion card, if present.4 Remove peripherals.5 Replace power supply.6 Replace logic board. Retain customer's SIMMs.





Vertical lines, horizontal lines, or snow appears on screen, or screen is completely dark; startup tone is normal

- 1 Replace video cable.
- 2 Replace monitor.
- 3 Replace VRAM SIMM. Refer to Hardware/Memory
- 4 Replace logic board. Retain customer's SIMMs.
- 5 Replace power supply.





Floppy Drive

- | | |
|--|--|
| Audio and video are present, but internal drive does not operate | <ol style="list-style-type: none">1 Replace floppy drive cable.2 Replace floppy drive.3 Replace logic board. Retain customer's SIMMs. |
| Disk ejects; display shows Mac icon with blinking "X" | <ol style="list-style-type: none">1 Replace disk with known-good system disk.2 Replace floppy drive cable.3 Replace floppy drive.4 Replace logic board. Retain customer's SIMMs. |
| Disk does not eject | <ol style="list-style-type: none">1 Switch off system and hold mouse button down while switching system back on.2 Eject disk manually by pushing opened paper clip into hole beside drive slot.3 Replace floppy drive cable.4 Replace floppy drive. |





Drive attempts to eject disk, but doesn't

- 1 Push disk completely in.
- 2 Eject disk manually by pushing opened paper clip into hole beside drive slot.
- 3 Remove top cover and try ejecting disk. If disk ejects, be sure top cover is replaced correctly and securely.
- 4 Replace floppy drive.





Hard Drive

Internal hard drive runs continuously

- 1 Make sure System is version 7.0.1 (or later) for Macintosh Performa 400 or version 7.1 or later for other Performa 400 Series computers.
- 2 Replace internal hard drive.
- 3 Replace logic board. Retain customer's SIMMs.

Internal hard drive does not operate

- 1 Replace hard drive data cable.
- 2 Replace hard drive power cable.
- 3 Replace internal hard drive.
- 4 Replace logic board. Retain customer's SIMMs.





Peripherals

Works with internal or external SCSI device but does not work with both

- 1 Verify that SCSI select switch on external device is set to different priority from internal.
- 2 Verify that external SCSI devices are properly terminated.
- 3 Replace terminator on external device.
- 4 Verify that terminator is installed on internal SCSI drive.
- 5 Replace SCSI select cable.

Cursor does not move

- 1 Reboot system.
- 2 Check mouse connection.
- 3 If mouse was connected to keyboard, connect mouse to rear ADB port and disconnect keyboard. If mouse works, replace keyboard.
- 4 If mouse does not work in any ADB port, replace mouse.
- 5 Replace logic board. Retain customer's SIMMs.





- | | |
|--|---|
| Cursor moves, but clicking mouse button has no effect | <ol style="list-style-type: none">1 Replace mouse.2 Replace logic board. Retain customer's SIMMs.3 If mouse was connected to keyboard, connect mouse to rear ADB port and disconnect keyboard. If mouse works, replace keyboard.4 If mouse does not work in any ADB port, replace mouse. |
| Double-click doesn't open application, disk, or server | <ol style="list-style-type: none">1 Remove extra system files on hard drive.2 Clear parameter RAM. Hold down <Command> <Option> <P> <R> during startup but before "Welcome to Macintosh" appears.3 If mouse was connected to keyboard, connect mouse to rear ADB port and disconnect keyboard. If mouse works, replace keyboard.4 If mouse does not work in any ADB port, replace mouse.5 Replace logic board. Retain customer's SIMMs. |





No response to any key on keyboard

- 1 Make sure System is version 7.0.1 (or later) for Macintosh Performa 400 or version 7.1 or later for other Performa 400 Series computers.
- 2 Check keyboard connection to ADB port.
- 3 Replace keyboard cable.
- 4 Replace keyboard.
- 5 Replace logic board. Retain customer's SIMMs.

Known-good ImageWriter or ImageWriter II does not print

- 1 Make sure that Chooser and Control Panel settings are correct.
- 2 Make sure System is version 7.0.1 (or later) for Macintosh Performa 400 or version 7.1 or later for other Performa 400 Series computers.
- 3 Check printer DIP switches.
- 4 Replace printer interface cable.
- 5 Replace logic board. Retain customer's SIMMs.





Known-good
LaserWriter does not
print

- 1 Make sure that Chooser and Control Panel settings are correct.
- 2 Make sure System is version 7.0.1 (or later) for Macintosh Performa 400 or version 7.1 or later for other Performa 400 Series computers.
- 3 Refer to Networks and Communications manual.





Miscellaneous

Clicking, chirping,
or thumping

- 1 Replace power supply.
- 2 Disconnect hard drive. Replace drive if noise disappears.
- 3 Replace logic board. Retain customer's SIMMs.

System shuts down
intermittently

- 1 Make sure air vents on back and top of case are unobstructed. Thermal protection circuitry may shut down computer. After 30 to 40 minutes, system should be OK.
- 2 Replace power cable.
- 3 Replace power supply.
- 4 Replace SIMMs.
- 5 Replace logic board. Retain customer's SIMMs.





- | | |
|---|---|
| System intermittently crashes or locks up | <ol style="list-style-type: none">1 Make sure System is version 7.0.1 (or later) for Macintosh Performa 400 or version 7.1 or later for other Performa 400 Series computers.2 Make sure software is known-good.3 Replace SIMMs.4 Replace logic board. Retain customer's SIMMs.5 Replace power supply. |
| No sound from speaker | <ol style="list-style-type: none">1 Verify that volume setting in Control Panel is 1 or above.2 Replace speaker.3 Replace logic board. Retain customer's SIMMs. |
| Clock doesn't run | <ol style="list-style-type: none">1 Replace battery. See "Battery Replacement" in Additional Procedures.2 Replace logic board. Retain customer's SIMMs. |





System seems to boot; then message “Finder is old version” displays

Install newer version of system software.

System intermittently doesn't power on

- 1 Check cables.
- 2 Plug monitor directly into wall socket. Verify that monitor has power.
- 3 Try known-good keyboard and ADB cable.
- 4 Replace power cord.
- 5 Check batteries. See “Battery Verification” in Additional Procedures.
- 6 Replace logic board. Retain customer's SIMMs.

Monitor raster width too narrow

Refer to Adjustments section in appropriate Monitor manual for horizontal size (width) adjustment.





System hangs or crashes

- 1 Reinstall system software.
- 2 Be sure SCSI devices are properly connected.
- 3 If using an older LC Ethernet card, disable virtual memory.
- 4 Upgrade the ROMs on the Ethernet card.
- 5 Replace hard drive.
- 6 Replace logic board.

System doesn't recognize more than 10 MB of RAM

Although you can install up to 12 MB of RAM in Performa 400/405/410/430 computers, 10 MB is the maximum amount of RAM that the system recognizes.





Take Apart

Macintosh Performa 400 Series





Cover

No preliminary steps are required before you begin this procedure.

- 1 Remove the case screw if one is present.
- 2 Lift the tabs at the back of the lid. Lift the cover straight up.

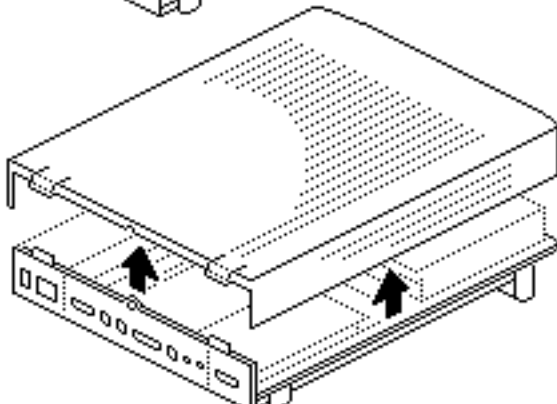
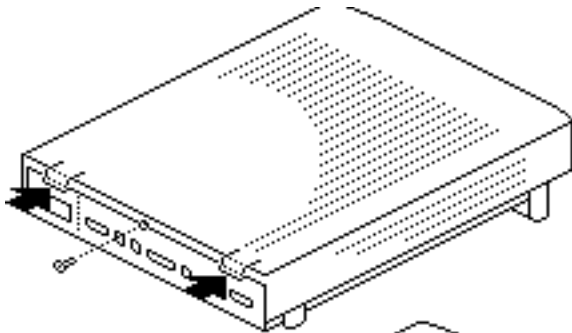



Hard Drive

Before you begin, remove the cover.

Caution: Review the ESD precautions in Bulletins/Safety.

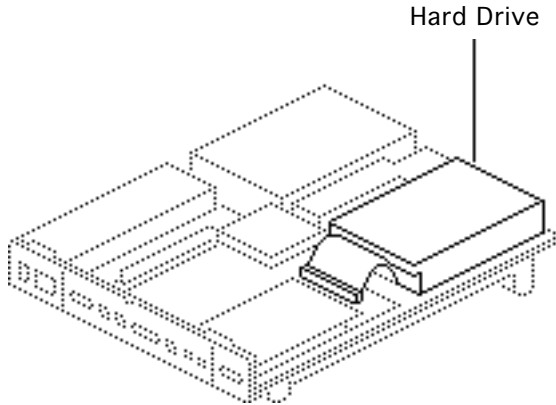

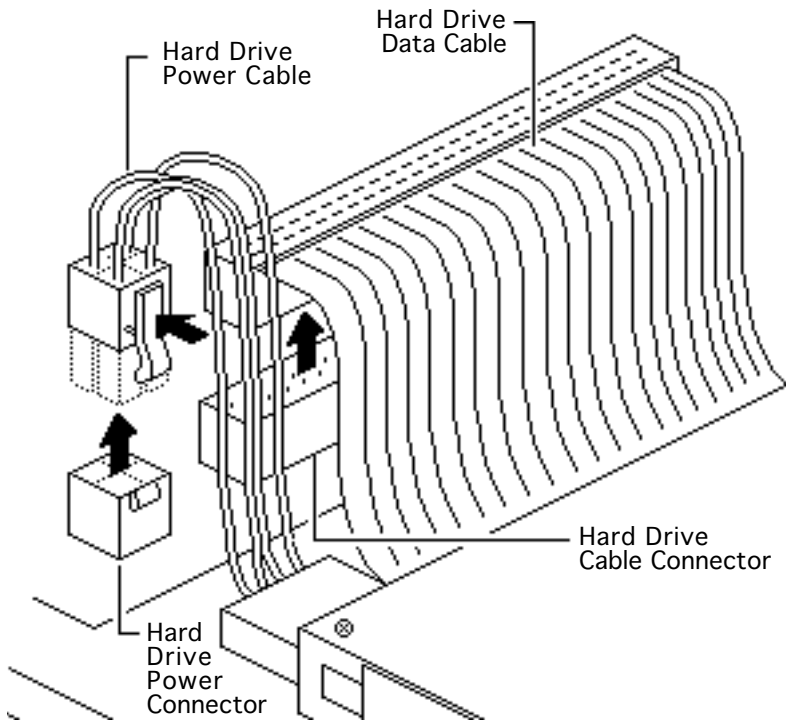

- 1 Release the locking tab and disconnect the hard drive power cable from the connector on the logic board.
- 2 Disconnect the hard drive data cable from the connector on the logic board.



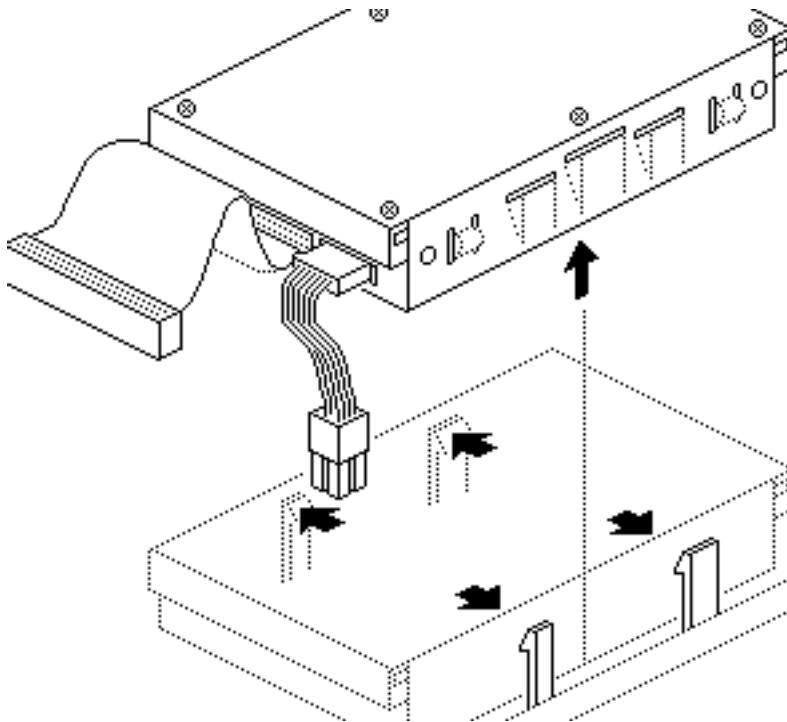

- 3 Release the two plastic latches on one side of the hard drive and lift the drive slightly. Repeat on the other side of the drive and remove the drive (with carrier) from the computer.

Replacement Note: For information on removing the hard drive from the carrier and returning drives, cables, and carriers to Apple, refer to “Additional Procedures” in the Hard Drives manual.





Fan

Before you begin, remove the cover.

Caution: Review the ESD precautions in Bulletins/ Safety.

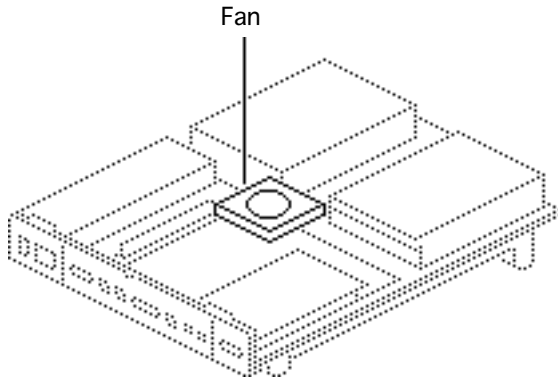

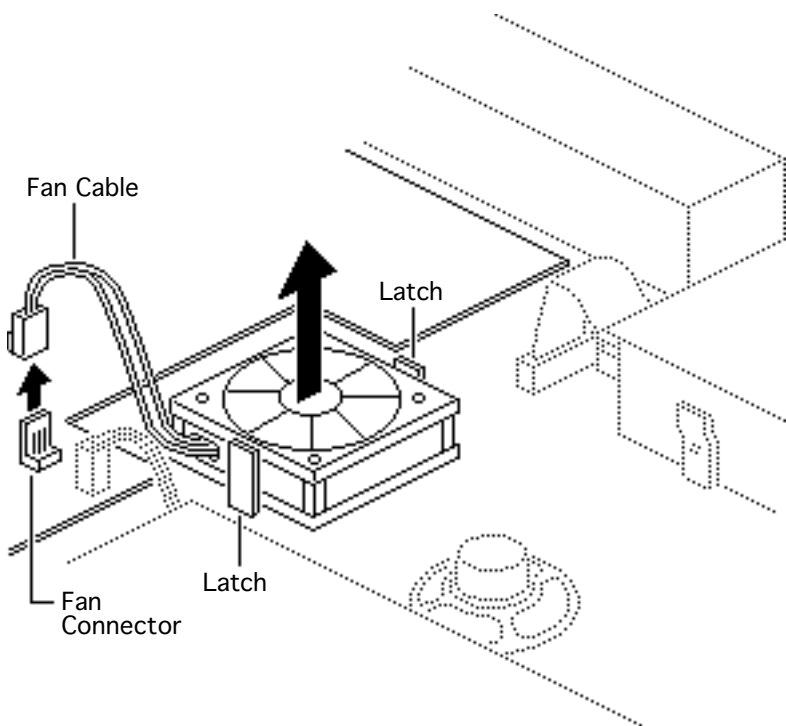

Disconnect the fan cable from the fan connector on the logic board.

- 1 Release the plastic latches and lift the fan from the case.

Replacement Caution: Be sure to install the fan with the logo side down, or the fan may damage the computer.





Speaker

Before you begin, remove the following:

- Cover
- Hard drive

Caution: Review the ESD precautions in Bulletins/Safety.

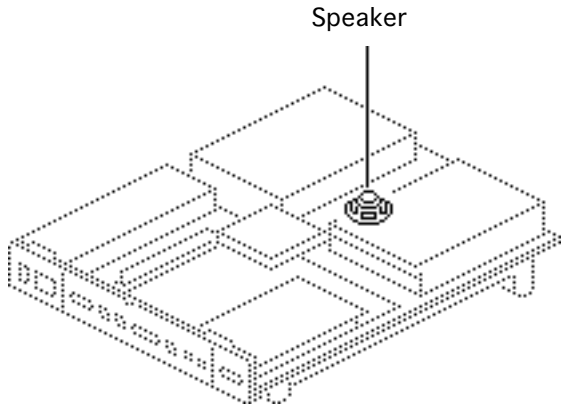

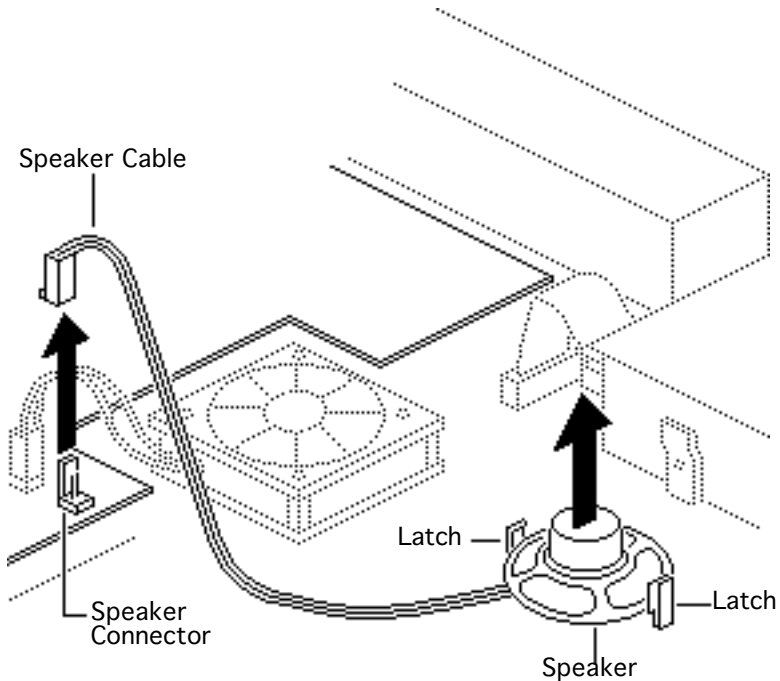

- 1 Disconnect the speaker cable from the speaker connector on the logic board.
- 2 Release the plastic latches and lift the speaker from the case.

Replacement Note: Before reconnecting the speaker cable, thread it through the top two brackets that hold the hard drive in place.





Floppy Drive

Before you begin, remove the cover.

Caution: Review the ESD precautions in Bulletins/ Safety.

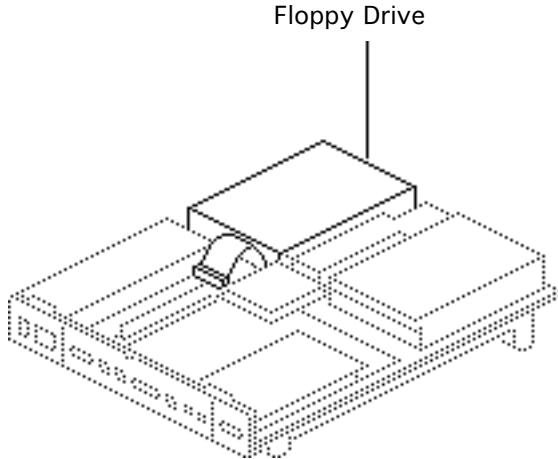

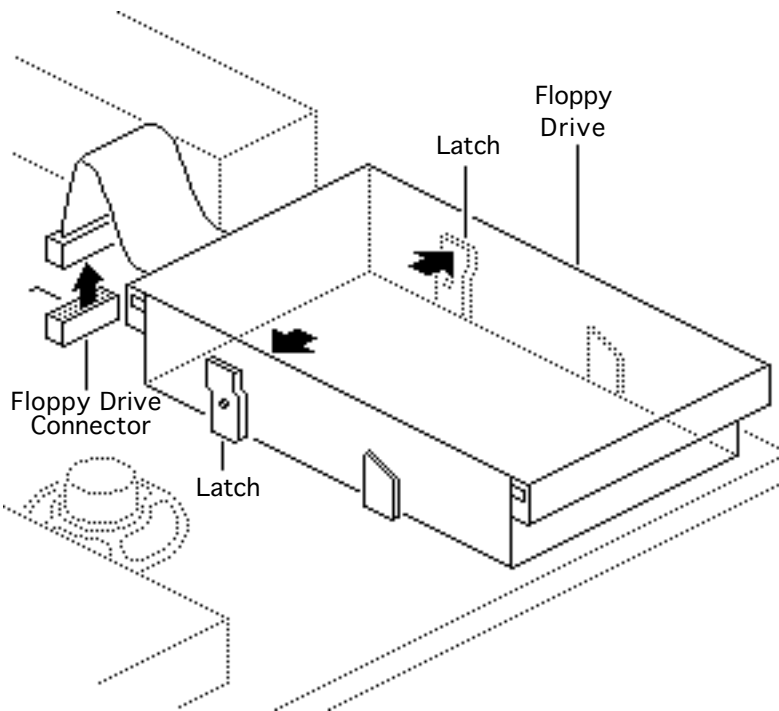

- 1 Disconnect the floppy drive cable from the connector on the logic board.
- 2 Release the two latches at the rear of the floppy drive and remove the drive from the case.

Replacement Note: Before you install a replacement 1.4 MB SuperDrive, you must remove the clear plastic dust shield, if present.





Replacement Note: You may encounter either an Apple SuperDrive or a manual eject floppy drive in some models. Replace floppy drives like for like.





Power Supply

Before you begin, remove the cover.

Caution: Review the ESD precautions in Bulletins/Safety.

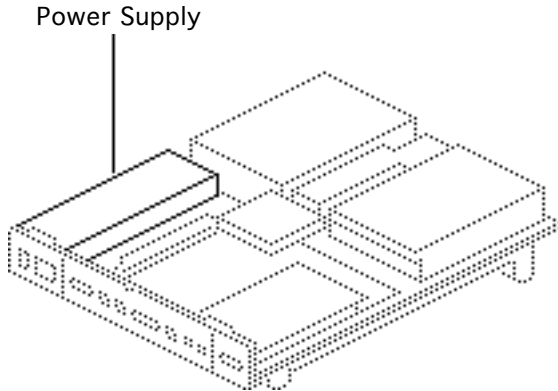

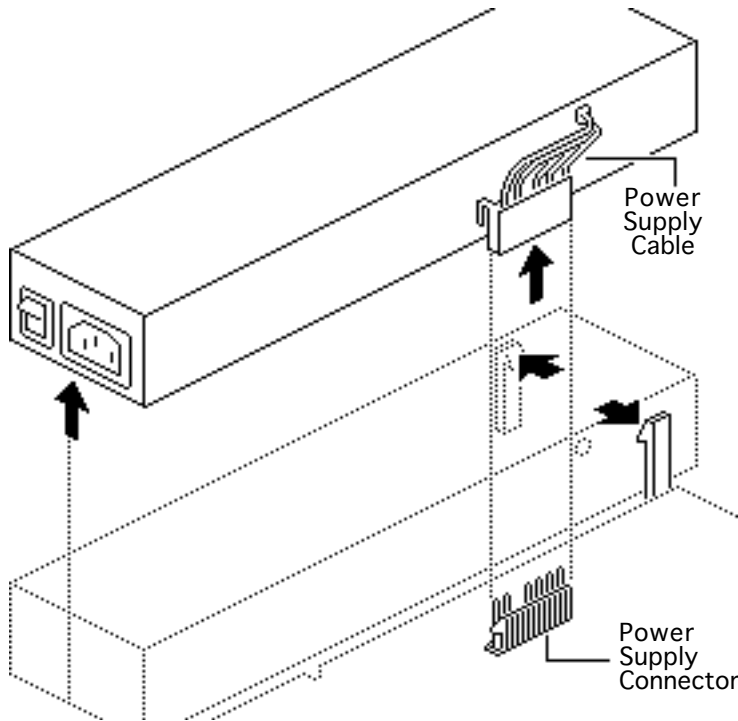

- 1 Disconnect the power supply cable from the connector on the logic board.
- 2 Release the two latches that secure the front end of the power supply to the bottom case, and lift the power supply out of the case.





Logic Board

Before you begin, remove the following:

- Coverover
- Fan

Caution: Review the ESD precautions in Bulletins/Safety.

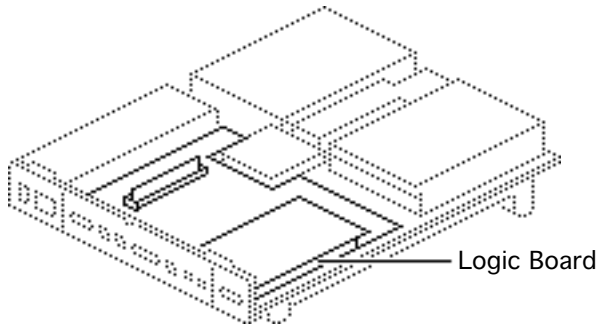

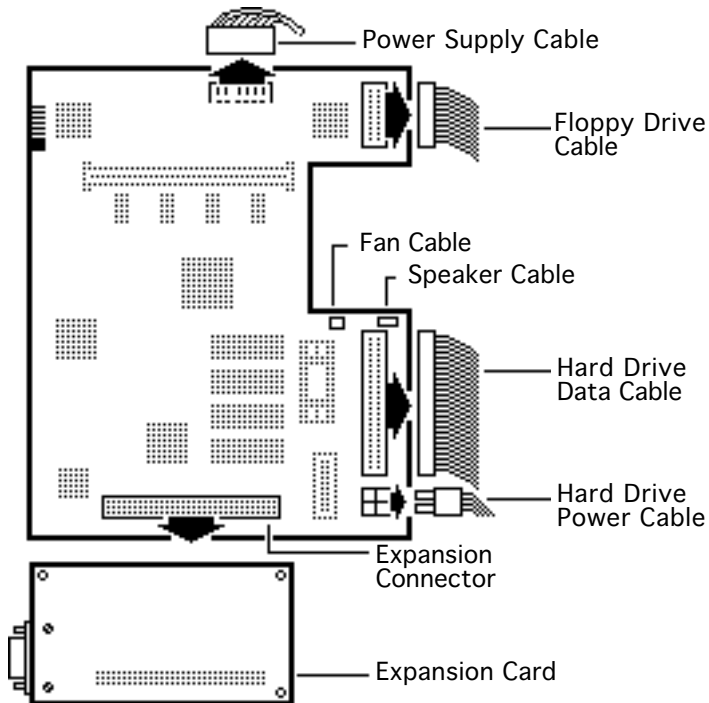

- 1 Disconnect the following cable connectors from the logic board:
 - Hard drive power cable
 - Hard drive data cable
 - Floppy drive cable
 - Power supply cable
 - Fan cable
 - Speaker cable
- 2 Remove the expansion card (if installed).





Important: In the next step, be sure the power on/off button clears the rear panel before you remove the logic board. While lifting the board, do not touch any components or connectors on the back of the logic board. (The oil from your skin can harm the connectors.)



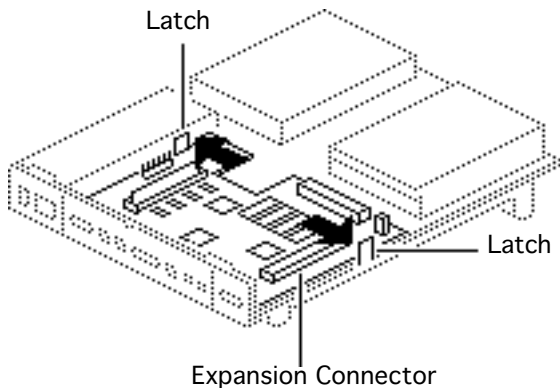

- 3 **Caution:** Using your forefingers, spread the two latches that secure the logic board to the bottom case. At the same time, using your right thumb, push on the expansion connector and slide the logic board toward the front of the case.





- 4 Gently lift the board from the case.

Replacement Note: Remove the SIMMs from the defective logic board and install them on the replacement logic board.

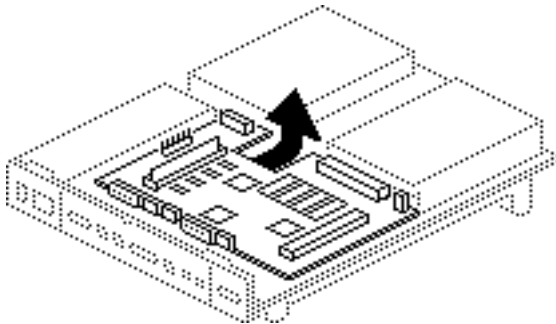



Upgrades

Macintosh Performa 400 Series





Macintosh Processor Upgrade

Before you begin, remove the following:

- I/O door
- Logic board
- Card in the PDS slot (if any)

Caution: Review the ESD precautions in Bulletins/ Safety.

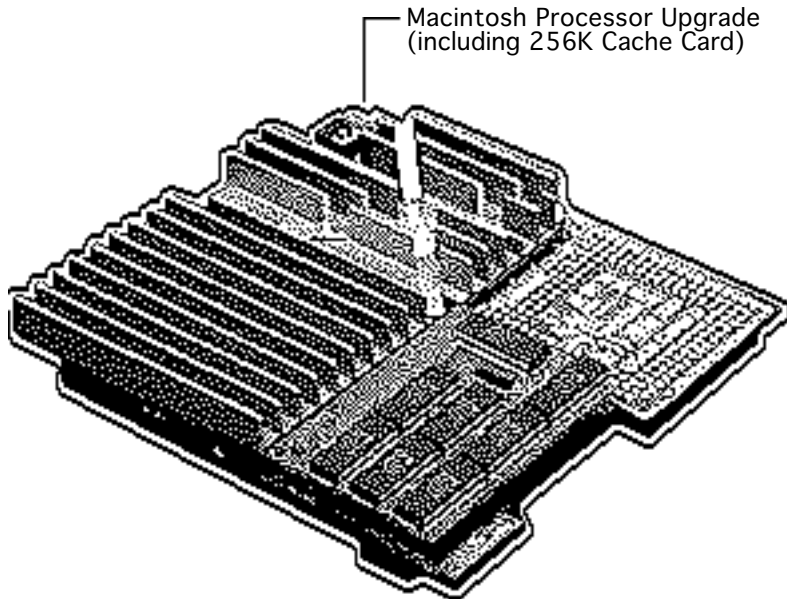



Note: The Macintosh Processor Upgrade kit allows 68LC040 computers to switch between a PowerPC 601 processor and a 68LC040 processor. The upgrade board includes the PowerPC 601 processor on board and a socket to accept the customer's 68LC040 processor.

Note: Refer to the Macintosh Processor Upgrade manual under the Power Macintosh menu for information about specifications and troubleshooting.



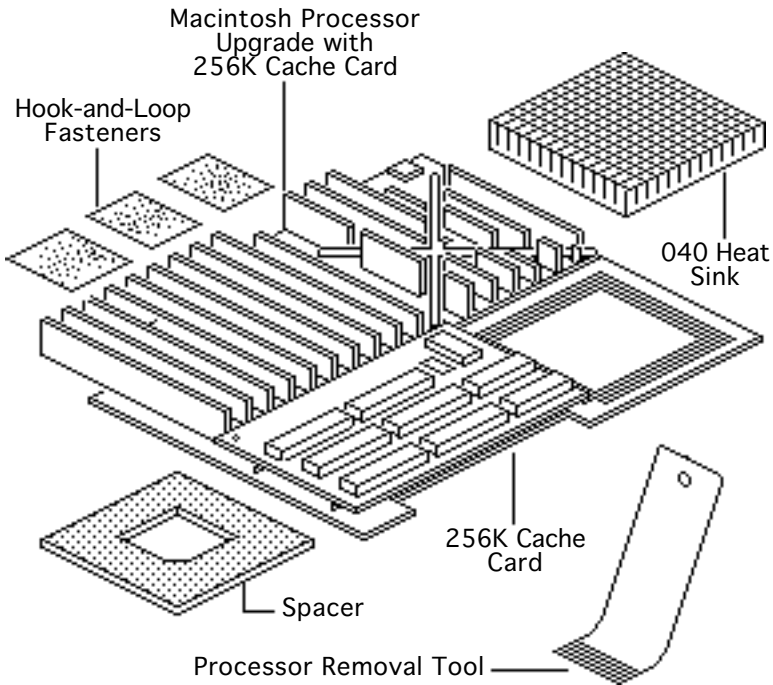

Note: The Macintosh Processor Upgrade comes packaged with the Macintosh Processor Upgrade board, 256K cache card, 040 heat sink, and hook-and-loop fasteners. If you need to order service replacement parts, order the parts separately.

Note: To install the upgrade, you will need a processor removal tool. Order the removal tool as a separate service part.





Note: The cache card comes installed on the upgrade board.





Installation Procedure Overview

There are three basic steps to installing the Macintosh Processor Upgrade on Performa 470 series computers.

- Remove the 68LC040 processor from the customer's logic board
- Install the 68LC040 processor on the upgrade board
- Install the upgrade board on the logic board

Detailed procedures follow.





Remove the 68LC040 Processor from the Logic Board

- 1 Locate the 68LC040 processor on the logic board.

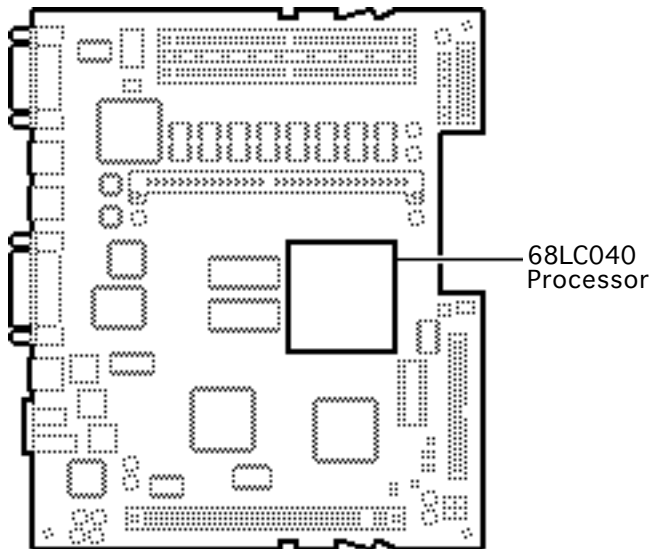

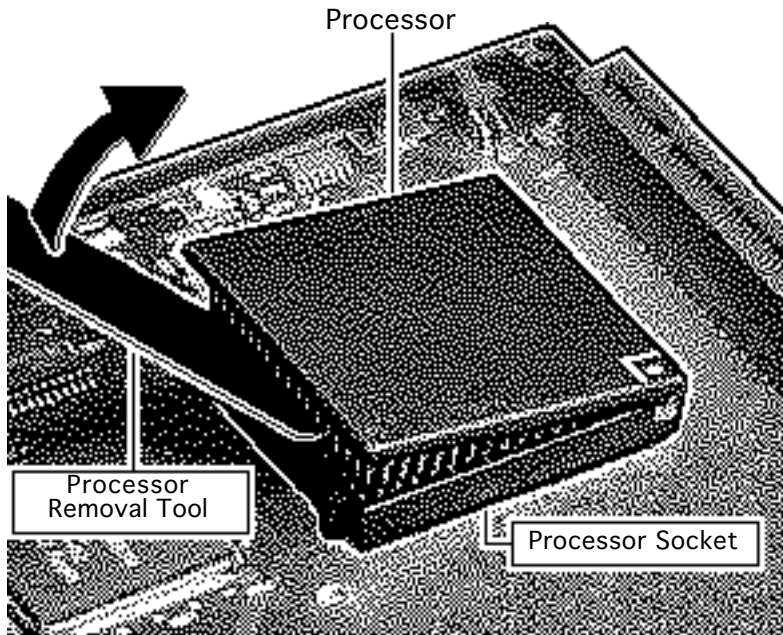

- 2 Position the teeth of the processor removal tool in the groove between the processor and the logic board socket.

Note: This graphic shows the proper way to remove any 68LC040 chip from its logic board. Your logic board may differ somewhat from this graphic.





Caution: Be sure to lift up on the handle of the processor removal tool. Pressing down could damage components on the logic board.

Caution: Pry up each side of the processor only slightly to avoid bending the pins.

- 3 Gently lift up the processor removal tool handle and pry up each side of the processor from the socket.
- 4 Remove the processor.



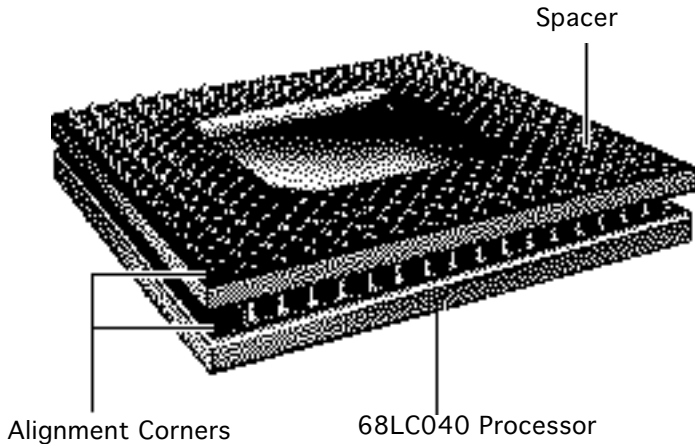

Install the 68LC040 Processor on the Upgrade Board

Note: The alignment corner of the 68LC040 processor is missing one pin. The alignment corner of the spacer is missing a pin hole.

- 1 Position the spacer alignment corner over the 68LC040 processor alignment corner
- 2 Place the spacer on the processor.



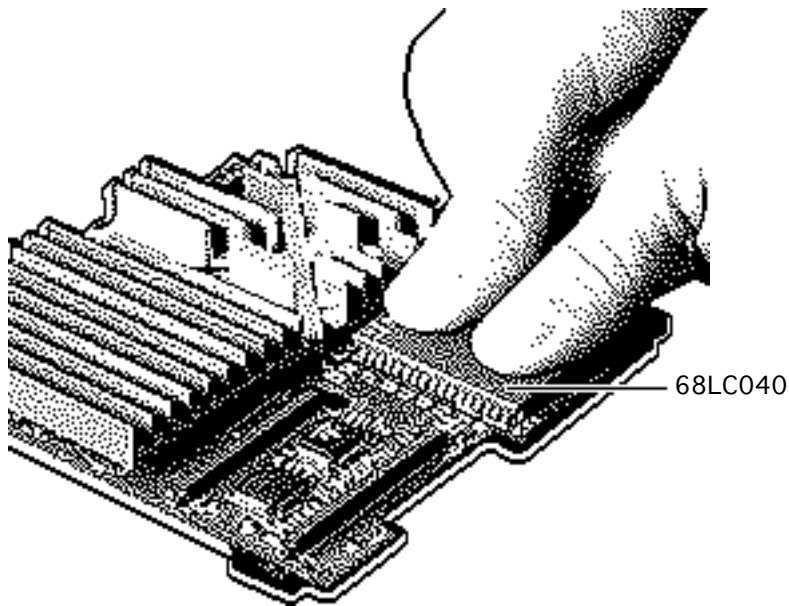

- Caution:** Forcing the 68LC040 processor connector pins into the socket could damage the pins. If the processor resists installation, check the pin alignment.

Caution: Place the upgrade board on a firm even surface to avoid bending the upgrade board when pressing the processor into the socket.





Caution: Use two thumbs to evenly distribute the pressure as you press the processor into the socket.

- 4 Hold the processor and spacer together and position the spacer alignment corner over the upgrade socket alignment corner.
- 5 Press the processor connector pins into the socket until you hear a “snap.”



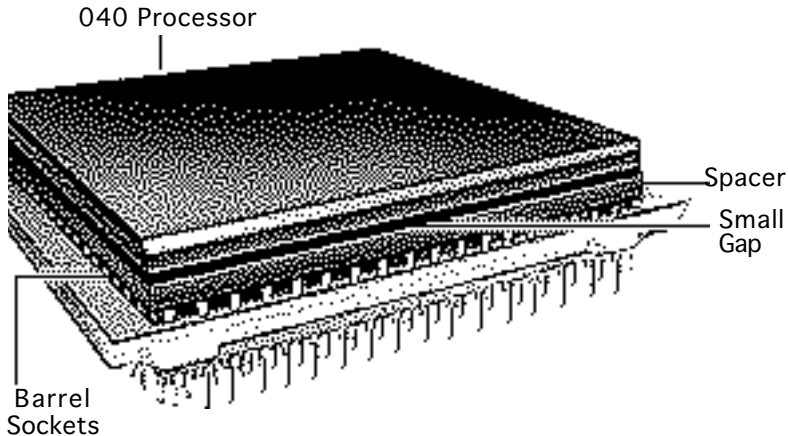

Note: On a correctly installed 040 processor, a very small gap separates the 040 chip from the metal spacer. A larger gap caused by the board barrel sockets separates the upgrade board and the spacer.



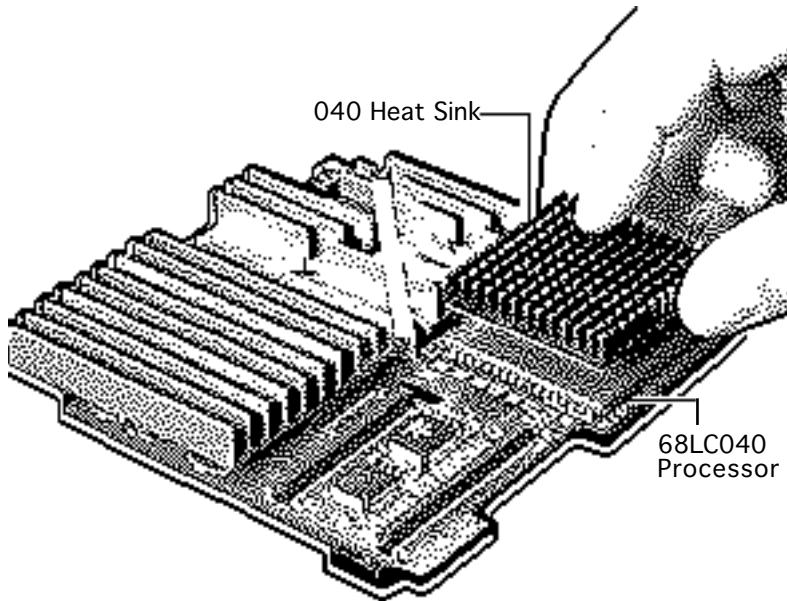

- 6 Peel the paper from the back of the heat sink and install the heat sink on the processor.

Note: Make sure the 040 heat sink is aligned with the sides of the processor.





Install the Upgrade Board

Note: The next step explains how to prepare the logic board to accept the upgrade board.

Caution: The EMI clips on the bottom of the Performa 470 series logic boards flex easily. Do not apply heavy pressure to the board or you may bend the logic board.



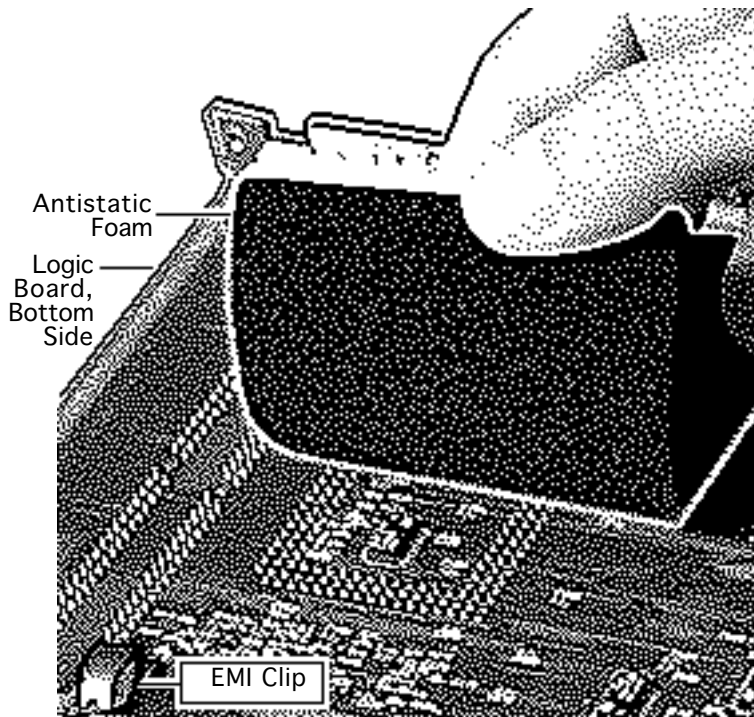

- 1 Place a piece of antistatic foam directly under the processor socket on the bottom side of the logic board.

Note: This step helps prevent the logic board from bending when you apply pressure in the next few steps.



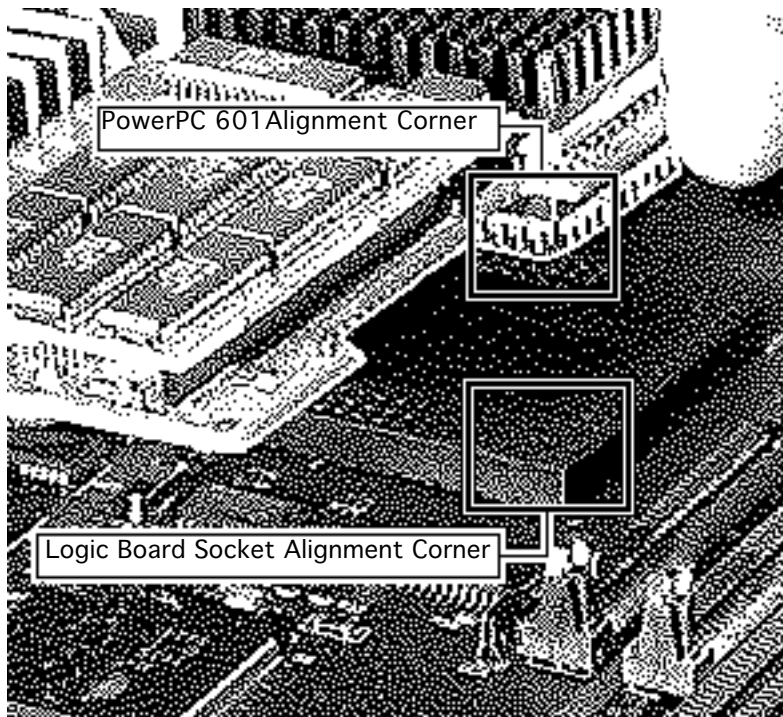

- 2 **Caution:** Forcing the upgrade board connector pins into the logic board socket could damage the pins. If the connector resists installation, check the pin alignment.

Position the upgrade connector alignment corner over the logic board socket alignment corner.

- 3 Carefully align the pins along all sides of the processor and socket.





- 4 Firmly press the connector pins into the logic board socket.

Note: To install the software, refer to the Macintosh Processor Upgrade Owner's Guide.





Logic Board and Upgrade Board Returns

Return the upgrade and logic boards to their original conditions before sending them to Apple. Be sure to remove the upgrade board from the logic board and reinstall the 68LC040 processor on the logic board.

Replacement Caution: To avoid bending any pins when removing the 68LC040 processor, pry up each side only slightly.





Additional Procedures

Macintosh Performa 400 Series





Battery Verification

Before you begin, remove the cover.

Caution: Review the ESD precautions in Bulletins/Safety.

Warning: If handled or discarded improperly, the lithium battery in the computer could explode. Review battery handling and disposal instructions in Bulletins/Safety.

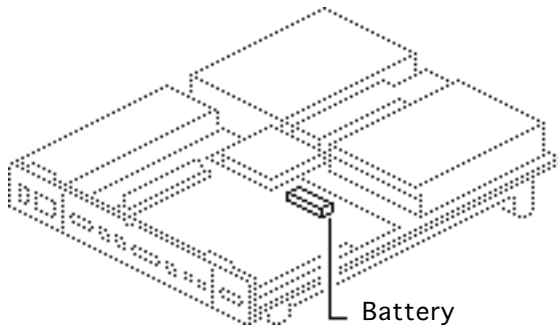

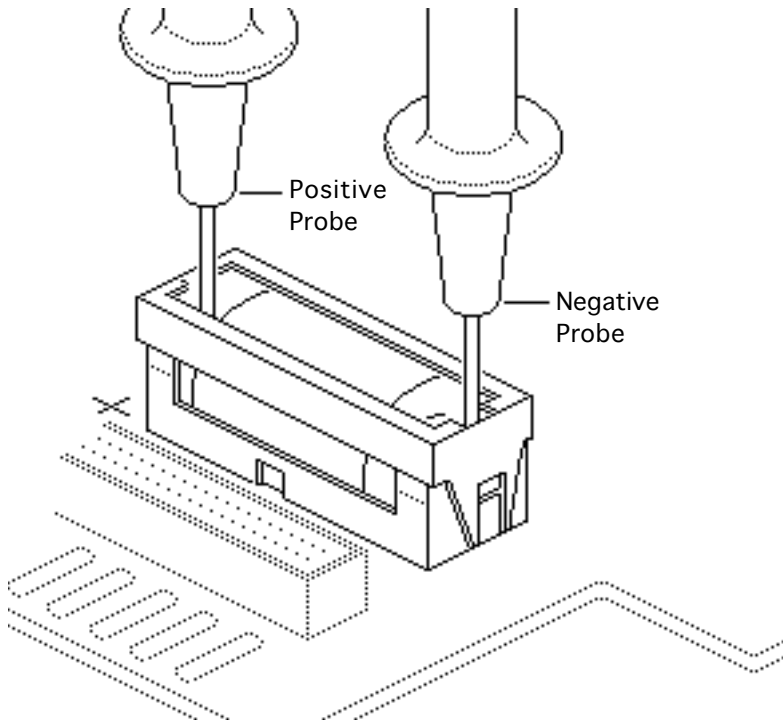

- 1 Set the voltmeter to the 10 volts DC scale.
- 2 Hold the positive probe of the voltmeter to the positive end of the battery and the negative probe to the negative end of the battery.
- 3 If the battery voltage is below 3.0 volts, replace the battery. Refer to “Battery Replacement” in this chapter.





Battery Replacement

Before you begin, remove the cover.

Caution: Review the ESD precautions in Bulletins/Safety.

Warning: If handled or discarded improperly, the lithium battery in the computer could explode. Review battery handling and disposal instructions in Bulletins/Safety.

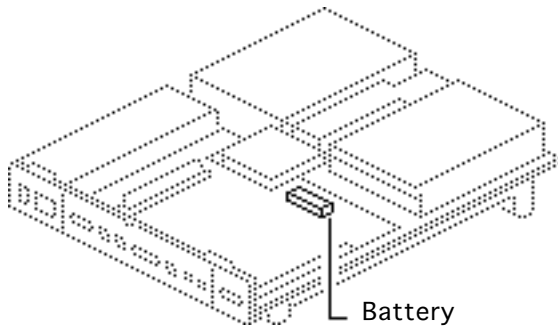

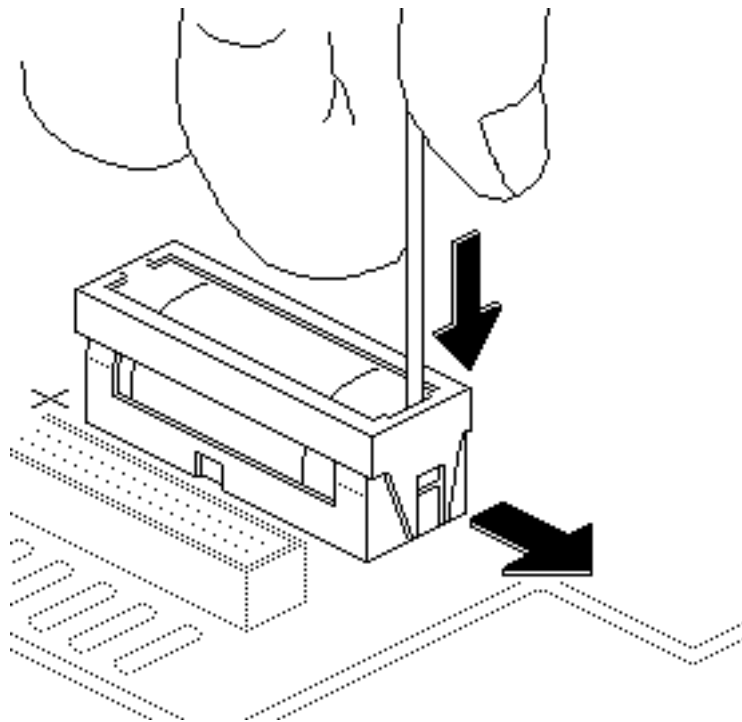

- 1 Insert a small flat-blade screwdriver into the top of the holder and gently push the screwdriver down until the side tab pushes out.
- 2 Repeat on the other end and remove the cover from the holder.



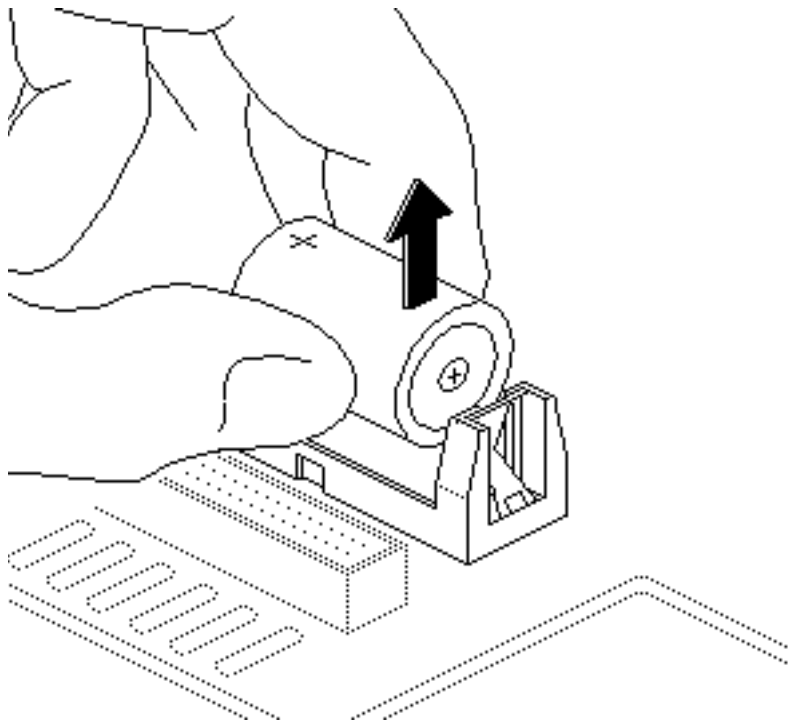

- 3 Grasp the battery and remove it from the holder.
- 4 Return the battery to Apple for proper disposal. For battery packaging and labeling information, refer to the instructions in Bulletins/Safety.





Exploded View

Macintosh Performa 400 Series



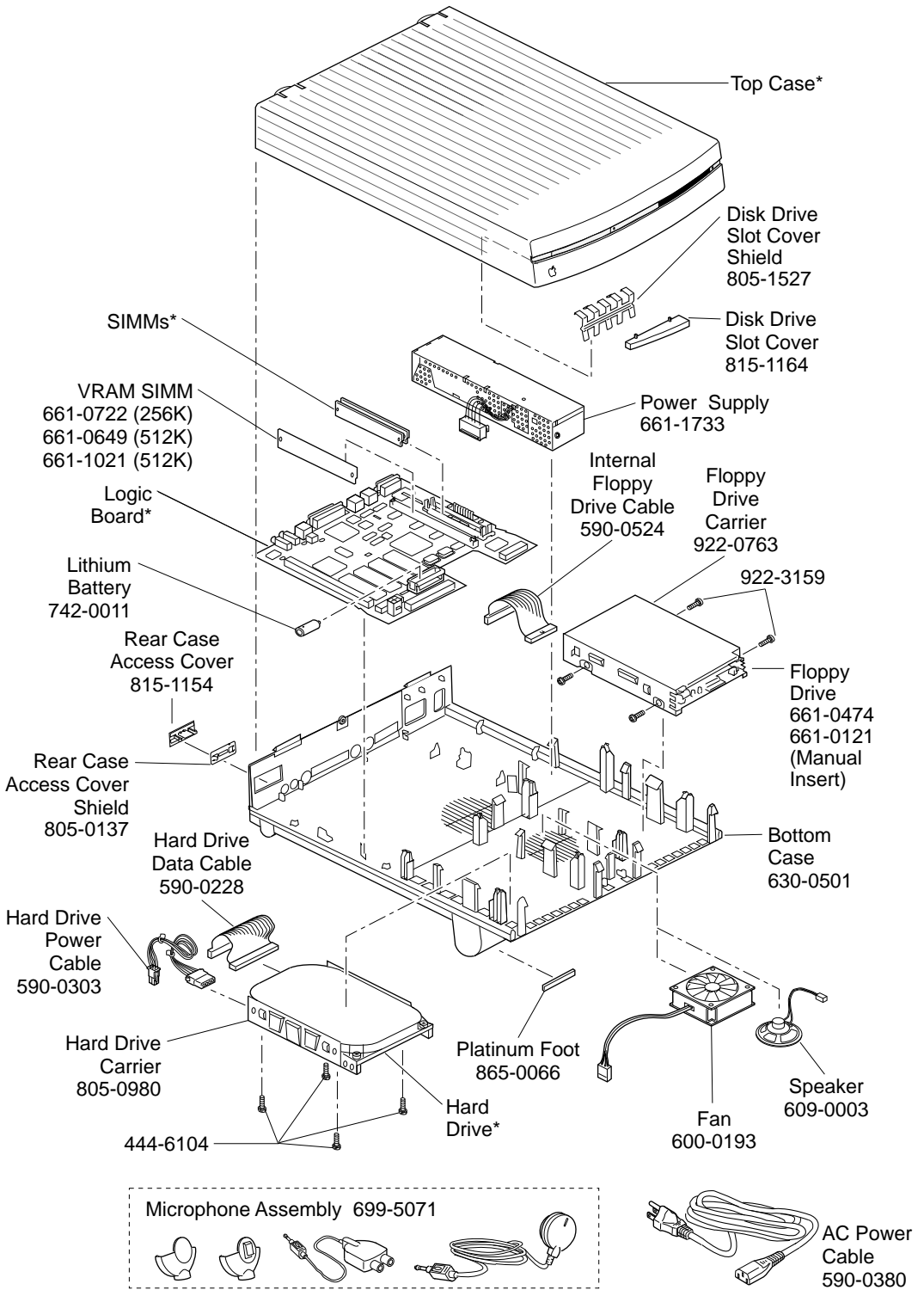

This is a generic representation of a product family. Configurations may vary. For number of part with asterisk, see parts list.

